

SERVICE

Your Soundstream MPQ-5XO Parametric Equalizer is protected by a limited warranty. Please read the enclosed warranty card for details. As with all Soundstream products, a Return Authorization (available from Soundstream) is required for service of this Soundstream MPQ-5XO Parametric Equalizer.

SOUNDSTREAM[®]
T E C H N O L O G I E S

SPECIFICATIONS

4-Band Parametric range	SUB-BOOSTER 20~70 Hz, MID-BASS 150~400 Hz MID-RANGE 1.5~4KHz, HIGH 4~20 KHz
Subwoofer Crossover	50~250 Hz
Maximum Output Voltage	10V RMS
Operating Voltage	11-15V negative ground
THD	0.005%
S / N Ratio	120dB REF 1V INPUT
Frequency Response	10Hz-30KHz, +/-1dB
Stereo Separation	90dB /1KHz
Output Impedance	10K Ohms
Boost / Cut	18dB
Input impedance	50K OHMS
Input sensitivity	150mV
Headroom	20dB
Dimensions (W x D x H)	1-1/2" x 7-3/16" x 4-5/16" Inches

MPQ-5XO 4 Band 18dB Parametric Equalizer

Owner's Manual
and
Installation Guide

Congratulation!

You now own the **Soundstream MPQ-5XO** parametric equalizer, the product of an uncompromising design and engineering philosophy. Your **Soundstream MPQ-5XO** parametric equalizer will outperform any other parametric equalizer in the world.

To maximize the performance of your system, we recommend that you thoroughly acquaint yourself with its capabilities and features. Please retain this manual and your sales receipt for future reference.

Soundstream parametric equalizer are the result of American innovation and the highest quality control standards. When properly installed, they will provide you with many years of listening pleasure. Should your parametric equalizer ever need service or replacement due to the theft, please record the following information which will help protect your investment.

Model and Serial # _____

Dealer's Name _____

Date of Purchase _____

Installation Shop _____

Installation Date _____

CAUTION!

Prolonged listening at extremely high levels may result in hearing loss. Even though your car audio system with your new Soundstream MPQ-5XO parametric equalizer sounds better than anything you've ever heard, exercise caution to prevent hearing damage.

DESIGN FEATURES

Master volume control with up to 10 volts RMS of output.
Front/ rear fader control.
Four band parametric equalizer with 18dB Boost Cut.
Specific bandwidth for each band.
Low noise BI-FET op-amp design yields minimum distortion.
On-board 30V bi-polar switching power supply.
Subwoofer outputs and level controls.
Subwoofer frequencies adjustable 50Hz-250Hz.
AUX / CD input selector.
Universal half-DIN chassis for ease of installation.
Gold-plated RCA input output connectors.
20dB headroom eliminates signal overload.

EQUALIZER BACKGROUND

There are basically three types of equalizers: graphic, parametric and a hybrid of these two, often referred to as paragratic. Additionally, there are passive equalizers, which have no gain, active gain preamps, which have a gain stage usually with a volume control, and booster equalizers which we won't consider here since they are inferior passive equalizers with inexpensive IC amplifiers built-in.

As in state-of-the-art home audio systems the optimum system requires a dedicated preamp with enormous gain to drive the various power amplifiers. Since home audio amplifiers do not have adjustable sensitivity, they require a high output preamplifier to drive them to maximum levels.

This unit is the first production preamplifier to incorporate a specific bandwidth parametric equalizer with shelving control. With 18db boost or cut on its four bands, it can compensate for acoustic anomalies unique to the automotive environment. The MPQ-5XO easily becomes the 'Control Center' of any high-end mobile entertainment system.

CONTROLS

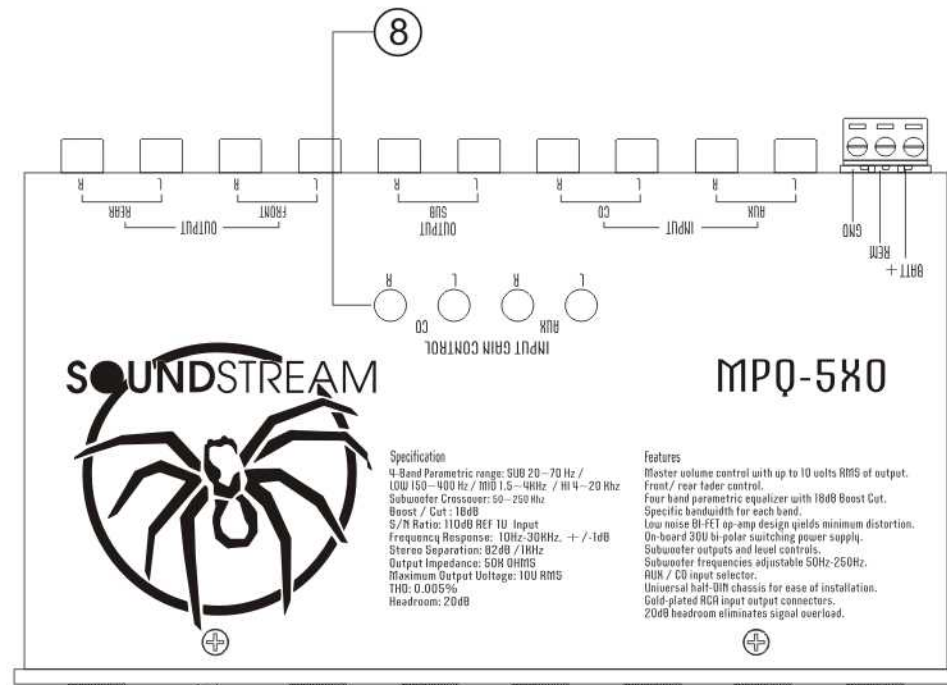
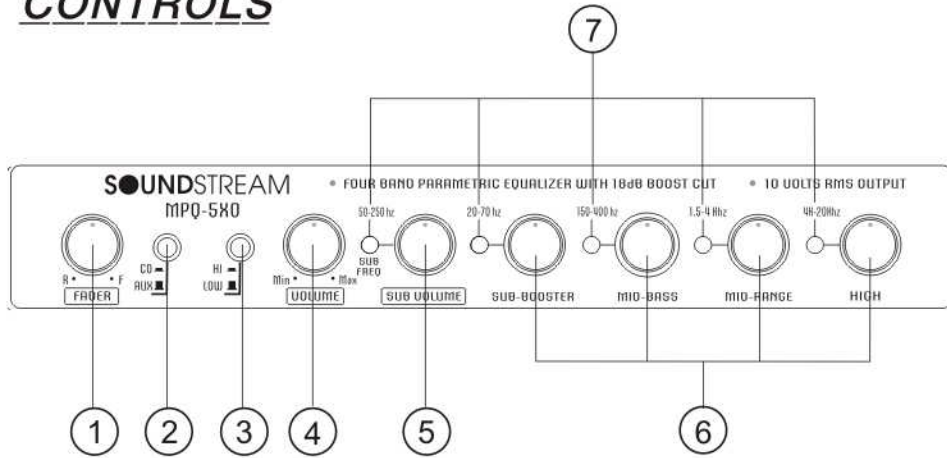

1. PREAMP FADER CONTROL

This control adjusts the volume between the front and rear output in 4-channel system.

2. INPUT SELECTOR SWITCH

This switch selects the AUX or CD input.

3. HIGH / LOW INPUT SELECTOR SWITCH

This switch selects the High or Low input.

4. MASTER VOUME CONTROL

This is the main control to adjust the output level.

5. SUBWOOFER VOLUME CONTROL

This adjusts the level of the subwoofer output.

6. FREQUENCY BAND CONTROLS

Adjust (cut or boost) the level of each frequency band up to +/-18dB.

7. CENTER FREQUENCY CONTROLS

With a mini flat head screwdriver, adjust each of the 5 center frequency controls.

8. INPUT GAIN CONTROLS

Independently adjust the left and right channel input sensitivity for each input (AUX and CD)

 Turn the knob clockwise to increase the input level.

 Turn the knob counter clockwise to reduce the input level.

ELECTRICAL INSTALLATION

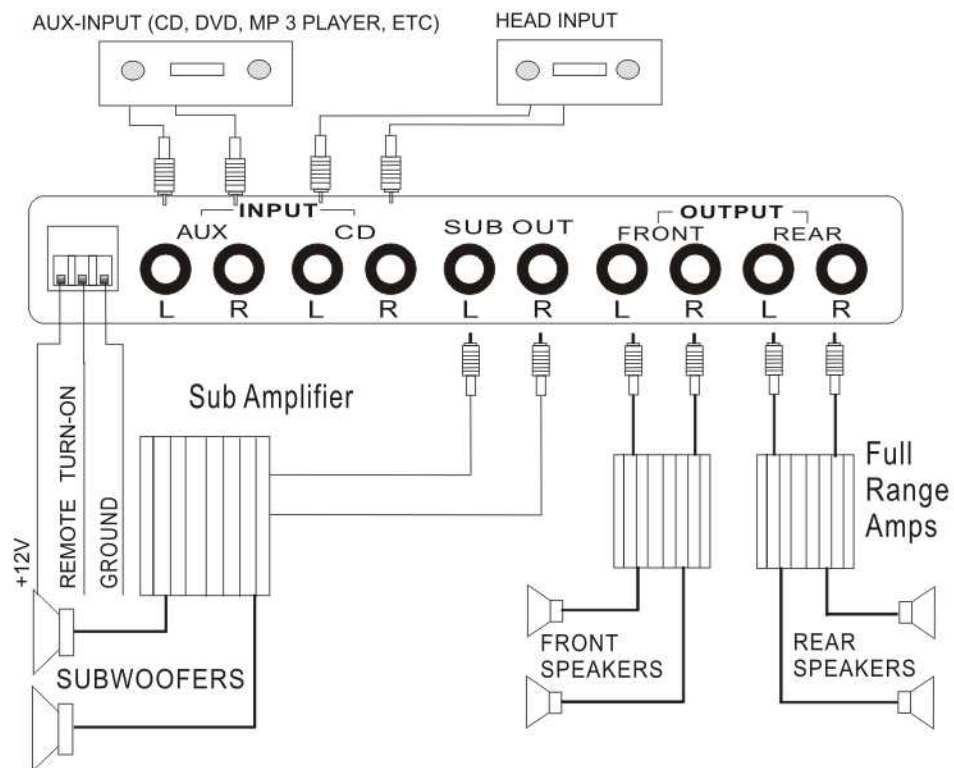

NOTES:

Set your source volume at one-half to three-quarters up and leave it. Always use the MPQ-5XO volume control as a master (main) volume control. This will allow you to take advantage of the MPQ-5XO's superior signal-to-noise ratio. Its volume control is more linear than any source unit volume control. If engine noise is audible, check the ground connection on all units in the audio system.

TROUBLE SHOOTING

Problem	Check
Signal Processor does not turn on.	<ul style="list-style-type: none"> • remote Turn-on wire has (+) 12V • (+) 12V wire has (+) 12V • Ground wire is properly connected
Level of sound is low.	<ul style="list-style-type: none"> • wiring is not loose or cables misconnected / disconnected • RCA cables are not faulty
Background noise is too high.	<ul style="list-style-type: none"> • wiring is not loose or cables misconnected / disconnected-ground is important • RCA cables are not faulty